

LDMOS RF Line Power FET Transistor 2 W , 800-2200 MHz, 28V

**Discontinued
(For Reference Only)**

Designed for broadband commercial applications up to 2.2GHz

- High gain, high efficiency and high linearity
- Ease of design for gain and insertion phase flatness
- Excellent thermal stability
- W-CDMA performance at 2.17GHz, 28Vdc
Average output power: 28dBm @ -39dBc ACPR
Gain: 14.5dB (typ.)
Efficiency: 23% (typ.)
10:1 VSWR ruggedness at 2W (CW), 28V, 2.11GHz
- Performance at 960MHz, 26Vdc, P_{1dB}
Average output power: 2W min.
Gain: 20dB (typ.)
Efficiency: 50% (typ.)
10:1 VSWR ruggedness at 2W, 26V, 960MHz

Product Image

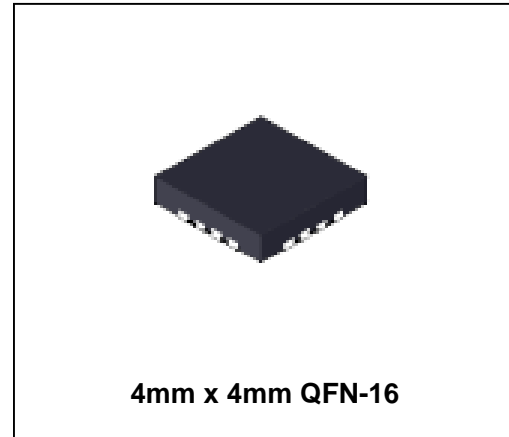

MAXIMUM RATINGS

| Parameter | Symbol | Rating | Units |
|--|------------------|-------------|-----------------|
| Drain—Source Voltage | V _{DSS} | 65 | V _{dc} |
| Gate—Source Voltage | V _{GS} | +15, -0.5 | V _{dc} |
| Total Power Dissipation @ T _C = 25 °C | P _D | 6.9 | W |
| Storage Temperature | T _{STG} | -65 to +150 | °C |
| Junction Temperature | T _J | 150 | °C |

THERMAL CHARACTERISTICS

| Characteristic | Symbol | Max | Unit |
|--------------------------------------|------------------|-----|------|
| Thermal Resistance, Junction to Case | R _{θJC} | 18 | °C/W |

NOTE—**CAUTION**—MOS devices are susceptible to damage from electrostatic charge. Precautions in handling and packaging MOS devices should be observed.

LDMOS RF Line Power FET Transistor
2 W , 800-2200 MHz, 28V

Discontinued
(For Reference Only)

| Characteristic | Symbol | Min | Typ | Max | Unit |
|---|---------------|-----|------|-----|------|
| DC CHARACTERISTICS @ 25°C | | | | | |
| Drain-Source Breakdown Voltage ($V_{GS} = 0$ Vdc, $I_D = 30$ μ Adc) | $V_{(BR)DSS}$ | 65 | — | — | Vdc |
| Gate Threshold Voltage ($V_{ds} = 26$ Vdc, $I_d = 25$ mA) | $V_{GS(th)}$ | 2 | — | 5 | Vdc |
| Gate Quiescent Voltage ($V_{ds} = 26$ Vdc, $I_d = 25$ mA) | $V_{GS(Q)}$ | 3 | — | 5 | Vdc |
| Drain-Source On-Voltage ($V_{gs} = 10$ Vdc, $I_d = 0.1$ A) | $V_{DS(on)}$ | — | 0.30 | — | Vdc |

| RF FUNCTIONAL TESTS @ 25°C (In M/A-COM Test Fixture) | | | | | |
|---|----------------|--|----|---|----|
| Common Source Amplifier Gain ($V_{DD} = 28$ Vdc, $I_{DQ} = 35$ mA, $f = 2170$ MHz, $P_{OUT} = 2$ W) | G_P | — | 14 | — | dB |
| Drain Efficiency ($V_{DD} = 28$ Vdc, $I_{DQ} = 35$ mA, $f = 2170$ MHz, $P_{OUT} = 2$ W) | EFF (η) | — | 38 | — | % |
| Input Return Loss ($V_{DD} = 28$ Vdc, $I_{DQ} = 35$ mA, $f = 2170$ MHz, $P_{OUT} = 2$ W) | IRL | — | -9 | — | dB |
| Output VSWR Tolerance ($V_{DD} = 28$ Vdc, $I_{DQ} = 35$ mA, $f = 2170$ MHz, $P_{OUT} = 2$ W, VSWR = 10:1, All Phase Angles at Frequency of Tests) | Ψ | No Degradation In Output Power Before and After Test | | | |

| RF FUNCTIONAL TESTS @ 25°C (In M/A-COM Test Fixture shown in Figure 10) | | | | | |
|---|----------------|--|------|---|----|
| Common Source Amplifier Gain ($V_{DD} = 26$ Vdc, $I_{DQ} = 35$ mA, $f = 1900$ MHz, $P_{OUT} = 2$ W) | G_P | — | 14.5 | — | dB |
| Drain Efficiency ($V_{DD} = 26$ Vdc, $I_{DQ} = 35$ mA, $f = 1900$ MHz, $P_{OUT} = 2$ W) | EFF (η) | — | 40 | — | % |
| Input Return Loss ($V_{DD} = 26$ Vdc, $I_{DQ} = 35$ mA, $f = 1900$ MHz, $P_{OUT} = 2$ W) | IRL | — | -10 | — | dB |
| Output VSWR Tolerance ($V_{DD} = 26$ Vdc, $I_{DQ} = 35$ mA, $f = 1900$ MHz, $P_{OUT} = 2$ W, VSWR = 10:1, All Phase Angles at Frequency of Tests) | Ψ | No Degradation In Output Power Before and After Test | | | |

(1) Device specifications obtained on a Production Test Fixture.

LDMOS RF Line Power FET Transistor
2 W , 800-2200 MHz, 28V

Discontinued
(For Reference Only)

| Characteristic | Symbol | Min | Typ | Max | Unit |
|---|----------------|--|-----|-----|------|
| RF FUNCTIONAL TESTS @ 25°C (In M/A-COM Test Fixture) | | | | | |
| Common Source Amplifier Gain ($V_{DD} = 26$ Vdc, $I_{DQ} = 35$ mA, $f = 1670$ MHz, $P_{OUT} = 2$ W) | G_P | — | 15 | — | dB |
| Drain Efficiency ($V_{DD} = 26$ Vdc, $I_{DQ} = 35$ mA, $f = 1670$ MHz, $P_{OUT} = 2$ W) | EFF (η) | — | 45 | — | % |
| Input Return Loss ($V_{DD} = 26$ Vdc, $I_{DQ} = 35$ mA, $f = 1670$ MHz, $P_{OUT} = 2$ W) | IRL | — | -11 | — | dB |
| Output VSWR Tolerance ($V_{DD} = 26$ Vdc, $I_{DQ} = 35$ mA, $f = 1670$ MHz, $P_{OUT} = 2$ W, VSWR = 10:1, All Phase Angles at Frequency of Tests) | Ψ | No Degradation In Output Power Before and After Test | | | |

| | | | | | |
|--|----------------|--|-----|---|----|
| RF FUNCTIONAL TESTS @ 25°C (In M/A-COM Test Fixture shown in Figure 12) | | | | | |
| Common Source Amplifier Gain ($V_{DD} = 26$ Vdc, $I_{DQ} = 50$ mA, $f = 960$ MHz, $P_{OUT} = 2$ W) | G_P | — | 20 | — | dB |
| Drain Efficiency ($V_{DD} = 26$ Vdc, $I_{DQ} = 50$ mA, $f = 960$ MHz, $P_{OUT} = 2$ W) | EFF (η) | — | 50 | — | % |
| Input Return Loss ($V_{DD} = 26$ Vdc, $I_{DQ} = 50$ mA, $f = 960$ MHz, $P_{OUT} = 2$ W) | IRL | — | -12 | — | dB |
| Output VSWR Tolerance ($V_{DD} = 26$ Vdc, $I_{DQ} = 50$ mA, $f = 960$ MHz, $P_{OUT} = 2$ W, VSWR = 10:1, All Phase Angles at Frequency of Tests) | Ψ | No Degradation In Output Power Before and After Test | | | |

LDMOS RF Line Power FET Transistor
2 W , 800-2200 MHz, 28V

Discontinued
(For Reference Only)

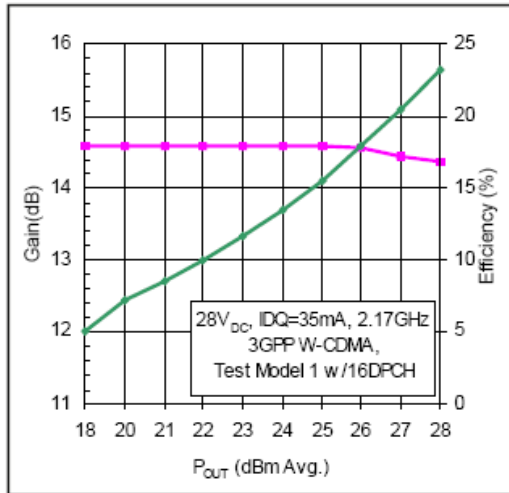

**W-CDMA: Gain and Efficiency vs Output Power
Graph 1.**

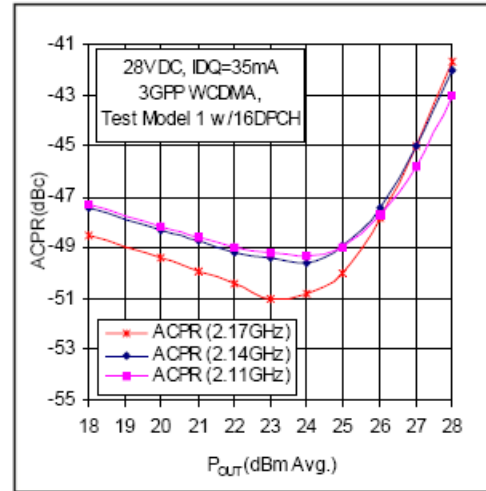

**W-CDMA: ACPR vs Output Power.
Graph 2.**

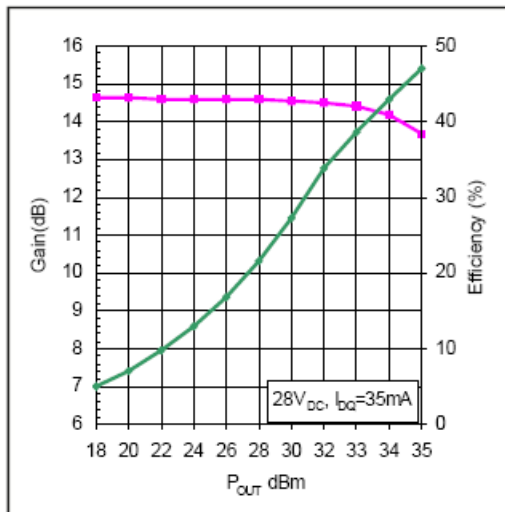

**CW: Gain and Efficiency vs Output Power
Graph 3.**

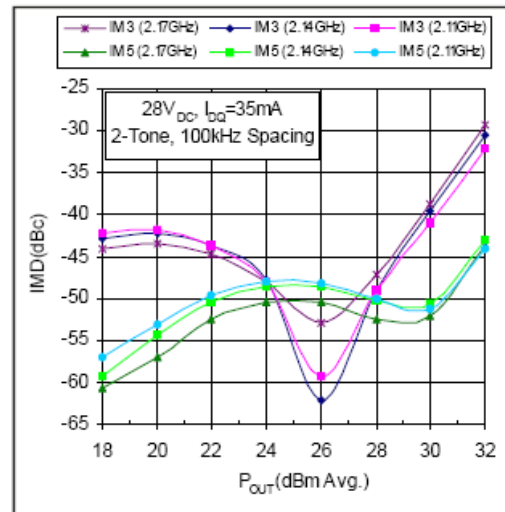

**Two Tone: Intermodulation Distortion vs Output Power
Graph 4.**

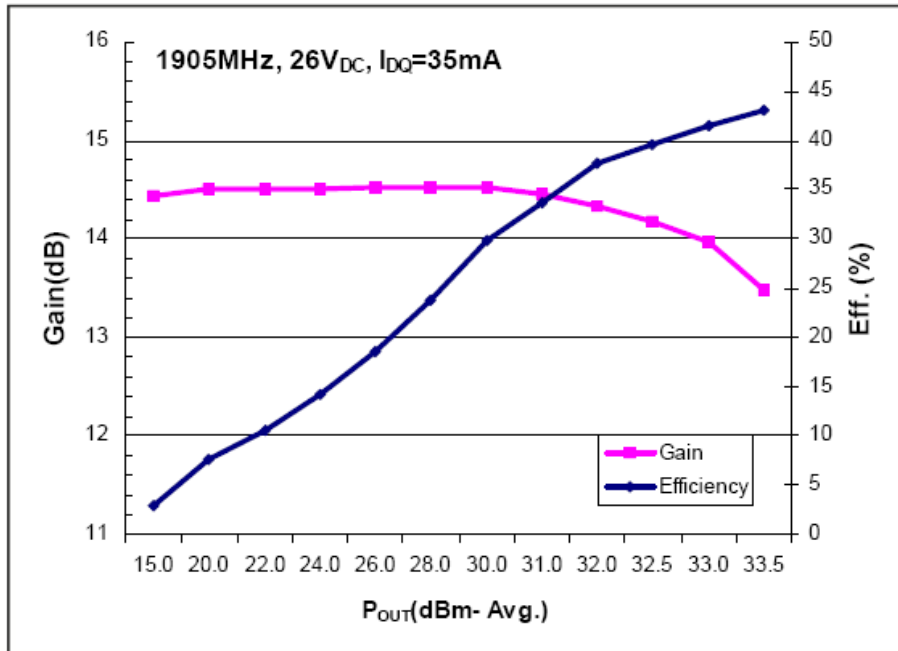

GRAPH 5. PHS POWER GAIN AND DRAIN EFFICIENCY VS. OUTPUT POWER

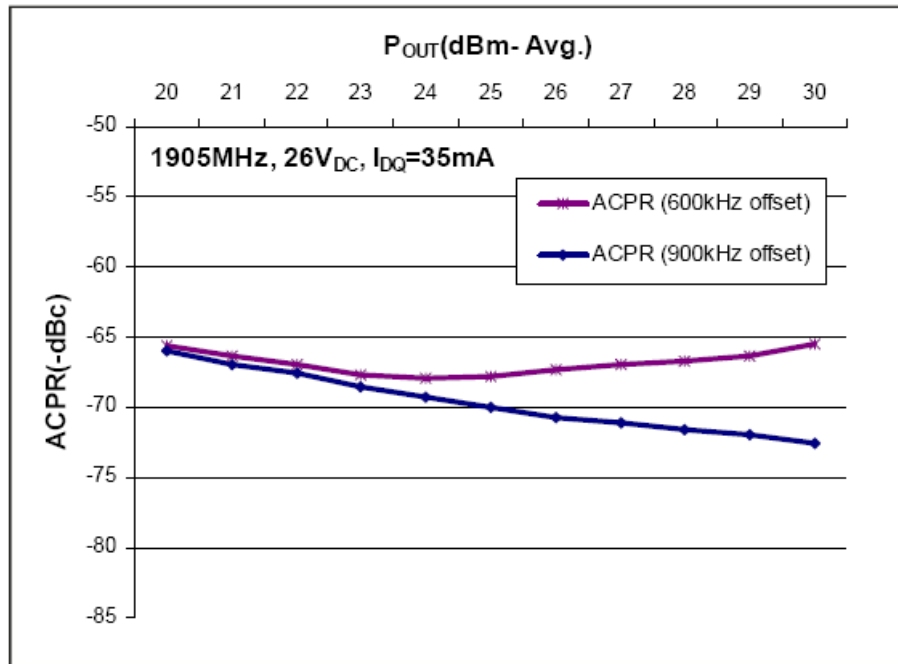

GRAPH 6. PHS ACPR VS. OUTPUT POWER

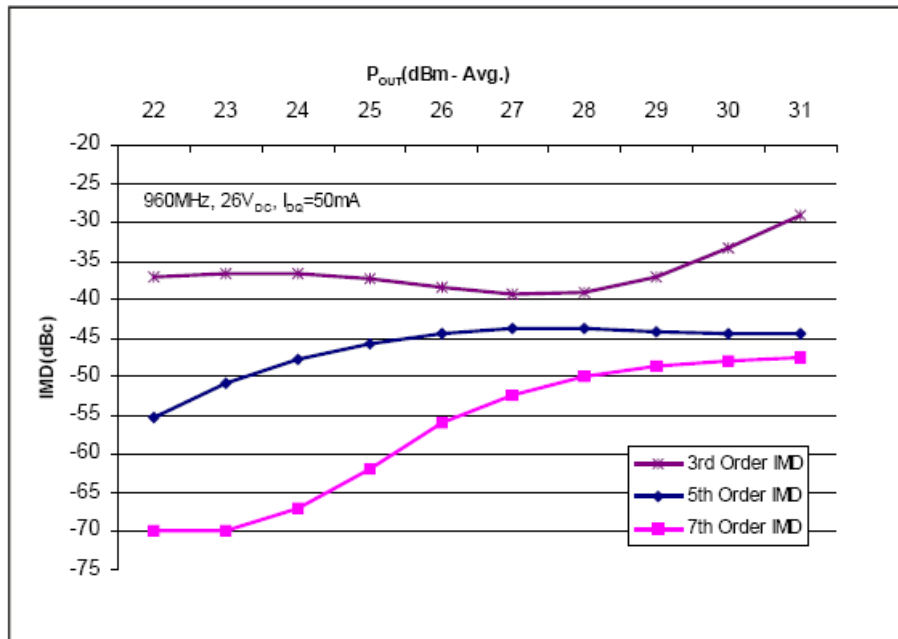
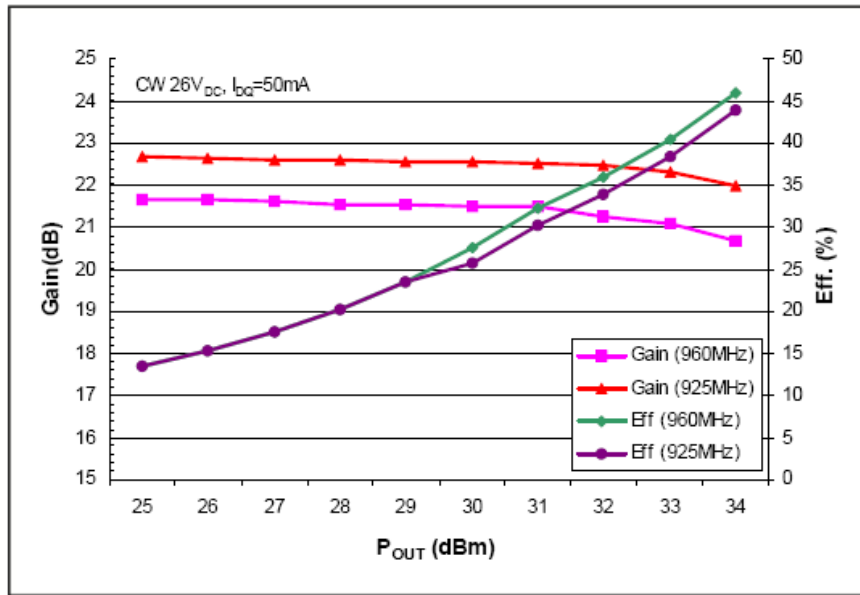

GRAPH 8. INTERMODULATION DISTORTION VS. OUTPUT POWER

LDMOS RF Line Power FET Transistor
2 W , 800-2200 MHz, 28V

Discontinued
(For Reference Only)

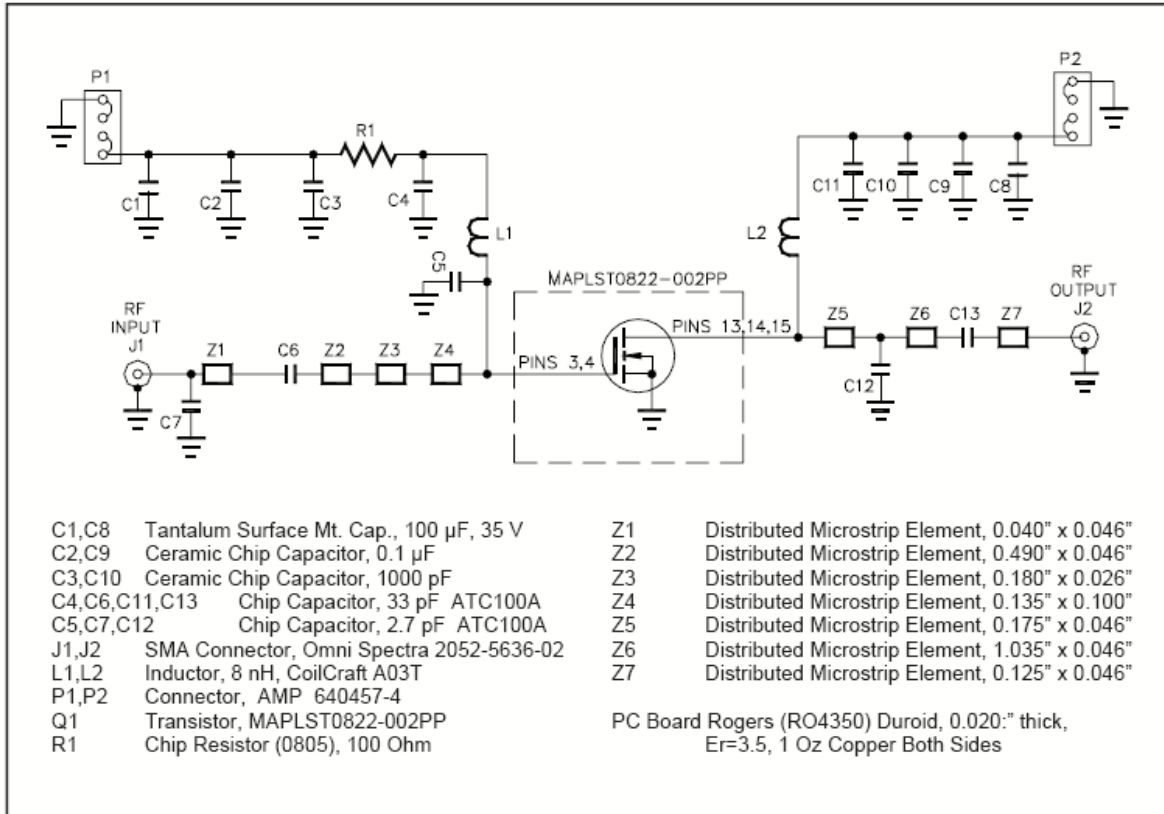

FIGURE 9. 1880—1920 MHz TEST FIXTURE SCHEMATIC

LDMOS RF Line Power FET Transistor
2 W , 800-2200 MHz, 28V

Discontinued
(For Reference Only)

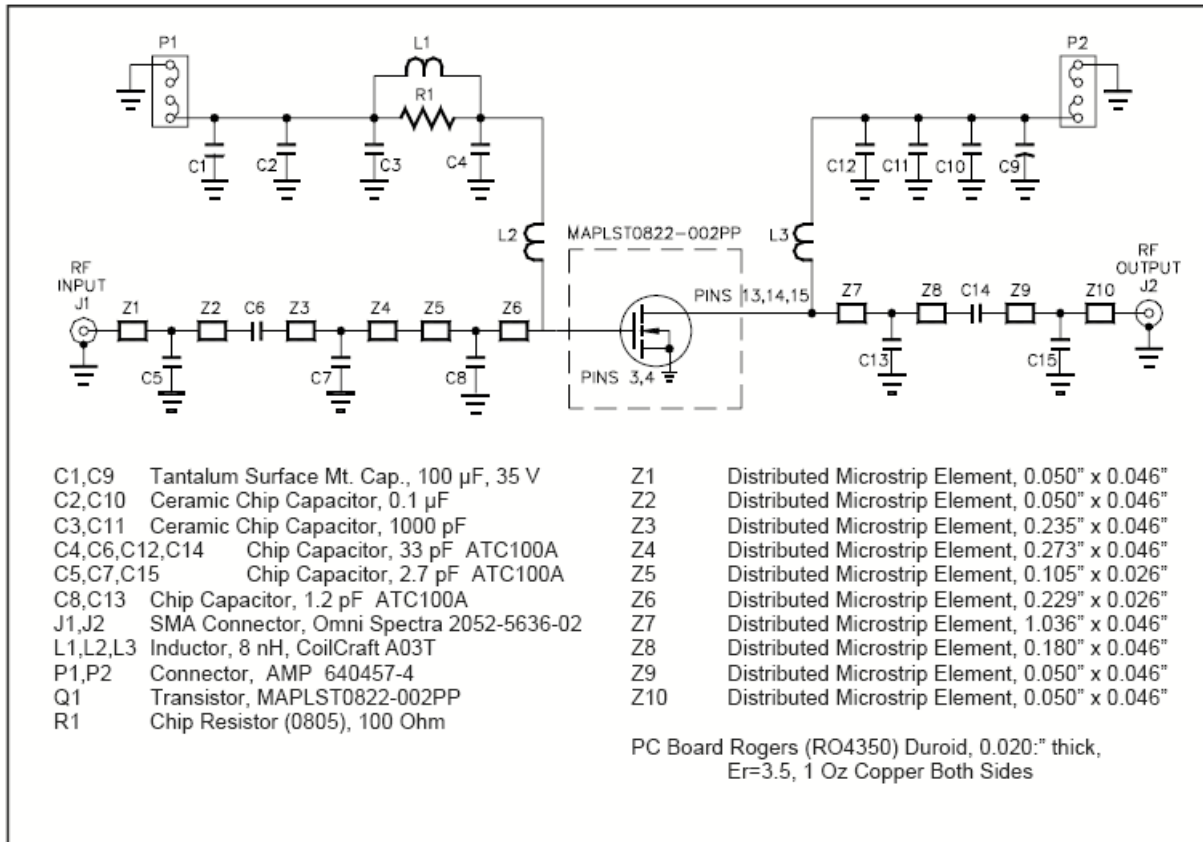

FIGURE 11. 920—960 MHz TEST FIXTURE SCHEMATIC

LDMOS RF Line Power FET Transistor
2 W , 800-2200 MHz, 28V

**Discontinued
(For Reference Only)**

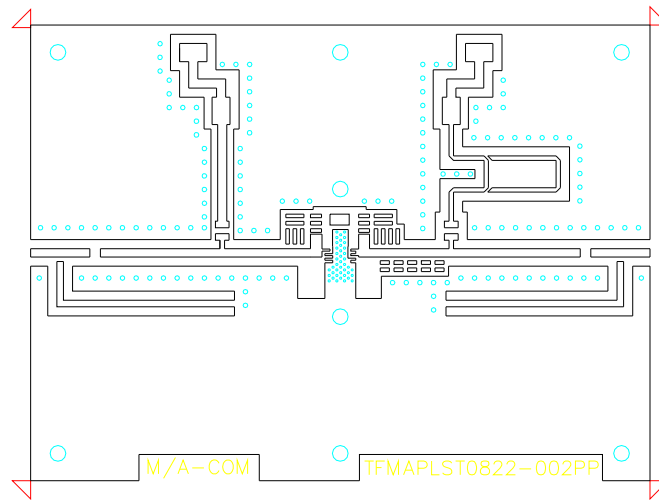
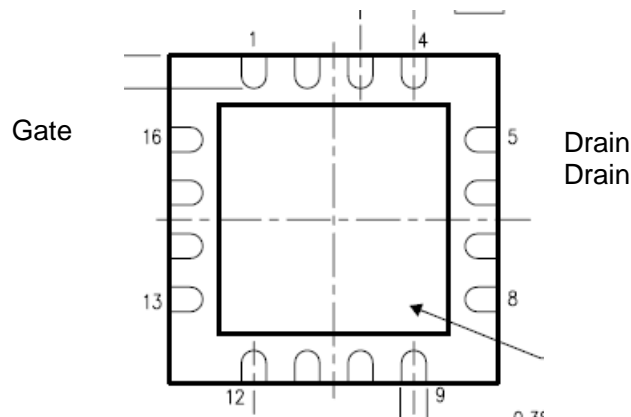

FIGURE 12. TEST FIXTURE PCB LAYOUT



Note: All other leads and bottom pad-
dle are connected to the Source

FIGURE 13. 4 MM X 4 MM QFN PIN CONNECTIONS

PACKAGE DIMENSIONS

